

Booster sets with a multistage pump suitable for pumping clean water without solid admixtures.

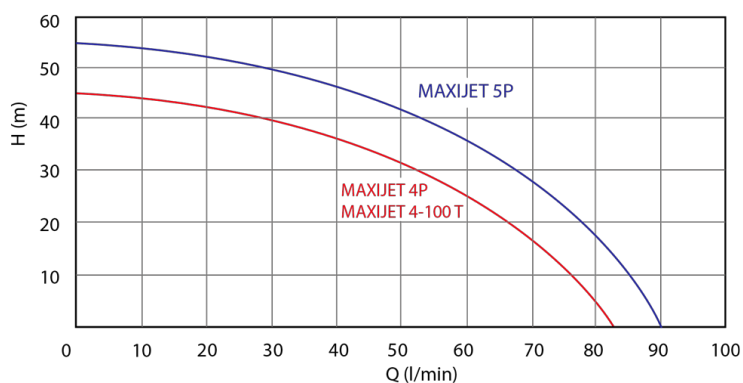

Construction characteristic

- stainless steel pump body
- suction and discharge parts made of cast iron
- distributor wheels made of technopolymer
- impellers from technopolymer
- Stainless steel shaft
- a mechanical seal made of graphite and a counterflange made of ceramics
- pressure vessel 24-100 lt
- pressure vessel bag of rubber

Motor

- closed, chilled outside
- IPX4 protection
- insulation class F
- single phase version with permanently built-in condenser
- thermal protection in the motor winding
- speed 2850 rpm
- flexicable 1,5 m

Usage

- type of liquid: pure water without solid additives and abrasive material
- max. pumped liquid temperature 40°C
- max. suction height with 7 m backflow valve
- max. working pressure 6 bar

Aplikace

- small pressure devices
- Booster setst
- irrigation

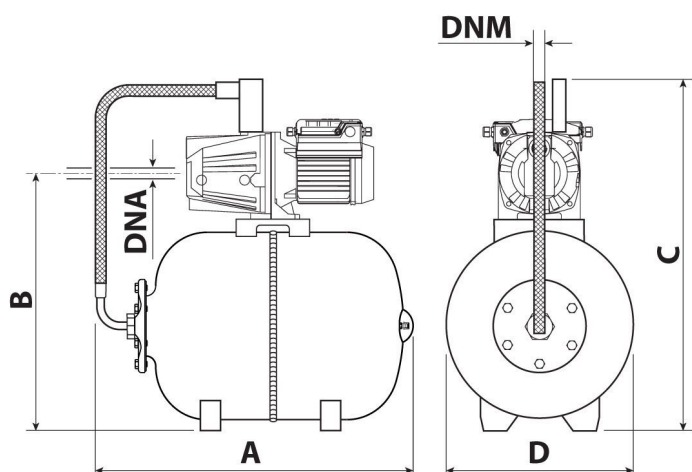

Type:	80
Power input:	1100 W
Q max:	6000 l/h
Head height:	48 m
Voltage:	230 V
Weight:	27 kg
Cable length:	1.5 m
A dimensions:	720 mm
B dimensions:	560 mm
C dimensions:	690 mm
D dimensions:	410 mm
DNA dimensions:	1"
DNM dimensions:	1"
Max. temperature:	40 °C
ON/OFF Pressure:	2 - 3,5 bar
Tank volume:	80 l
Suction height:	7 m
Max. over pressure:	6 bar